



RF Prototyping Module

- ◆ **For RF and Microwave Applications**
- ◆ **Decoupled and Filtered Power Lines from VXIbus Backplane**
- ◆ **Shielded RF Compartment**
- ◆ **Low Cost, 1 or 2-slot, C-size Modules**

RF Prototyping

Ideal for adding specific RF and Microwave modules into a VXIbus system. The 7066 decouples and filters the VXIbus backplane power lines for use within the shielded enclosure.

Maximum Prototype Area

This module enables RF components or sub systems to be conveniently added to a VXIbus system. RF/Microwave couplers, splitters, amplifiers or up-and-down- converters can be added to your system in this fully shielded module. If additional cooling is required, holes may be drilled in the modules shield to provide air circulation.

Add Microwave Functions to VXIbus Systems

This module enables RF components or sub systems to be conveniently added to a VXIbus system. RF/Microwave couplers, splitters, amplifiers or up-and-down- converters can be added to your system in this fully shielded module. If additional cooling is required, holes may be drilled in the modules shield to provide air circulation.

VXIbus Power is Accessible

The 7066 fully utilizes the available power from the VXIbus by connecting to multiple power pins on the P1 and P2 connectors. This gives you custom RF circuitry access to 7 A on the +5 V rail, 5 A on the -5.2 V rail and 1 A for all others. Single or double slot versions are available but only one row of P1/P2 connectors are used (i.e. no difference in power capability).

7066 PRODUCT SPECIFICATIONS

PROTOTYPING FEATURES

Breadboarding Space

11.58 in. (289 mm) x 8.36 in.(209 mm):
97 in 2

RF Compartment

Sealed (no cooling holes), either single or double (Opt. 01) wide.

Supplies to RF Compartment

+24 +12 +5 5.2 -12 -24
1A 1A 7A 5A 1A 1A

Lower voltages loss <10 mV/A Higher
voltages loss <20 mV/A

Power Supply Filtering

(insertion loss at specified frequency)

10 MHz: 20 db
100 MHz: 65 dB
500 MHz-1 GHz: 70 dB

OPTIONAL FEATURES

Option 01

Double Wide RF Compartment

VXIBUS INTERFACE DATA

Cooling (single slot)

21° C Rise with 40 W Dissipation in RF
Compartment.

ENVIRONMENTAL DATA

Temperature

Operating: 0° C to 50° C

Weight

Single Wide: x.yzbs. (x.ykg)
Double Wide: x.yzlbs. (x.ykg)

EMI

Meets MIL-STD-461C CEO3/REO3

EMC (Council Directive 89/336/EEC)

Meets CE requirement but dependent
upon added circuitry.

Safety (Low Voltage Directive 3/23/EEC)
EN6010-1, IEC1010-1, UL3111-1, CSA
22.2#1010

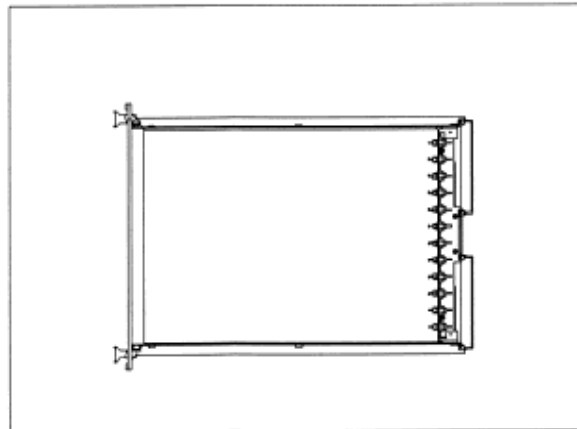

CE The CE Mark indicates that the product has completed and passed rigorous testing in the area of RF Emissions, Immunity to Electromagnetic Disturbances and complies with European electrical safety standards.

MODEL/DESCRIPTION

Racal Instruments 7066, Single Slot RF Prototype Module
Racal Instruments 7066-01, Double Slot RF Prototype Module
Racal Instruments 7066-02, Triple Slot RF Prototype Module

PART NUMBER

R-7066
R-7066/01
R-7066/02

The EADS North America Defense Test and Services policy is one of continuous development, consequently the equipment may vary in detail from the description and specification in this publication.



EADS North America Defense Test and Services
1.800.722.2528/1.949.859.8999 sales@eads-nadefense.com